

Tandem Axle for Round Baler

Bundle with 31.5-15 Tires RC0183
Bundle with 11L-14 Tires RC0181
Bundle without Tires RC0335



Parts Listing Service Information Installation Instructions

John Deere 6-Series, 7-Series and 8-Series Round Baler



Note: Balers with Push Bar and without *Mega Wide* Pickup require one (1) RC0185 Spacer Block Bundle.

Please retain this document for future reference.

RCI Engineering LLC
RC0199 (20Feb2010)
www.RCIEngineering.com

Table of Contents

1. Contents of Bundle.....	Pg. 3
1.1 Parts Listing.....	Pg. 4
2. Service Information.....	Pg. 5
2.1 Service Intervals.....	Pg. 5
2.2 Position of Pivot Assemblies for Various Baler Positions.....	Pg. 6
2.3 Spacer Location.....	Pg. 7
3. Installation of Tandem Axle Bundle.....	Pg. 7
3.1 Remove Tire and Spindle Assembly.....	Pg. 7
3.2 Install New Bolts in Main Frame of Baler.....	Pg. 8
3.3 Install Pivot Plate.....	Pg. 9
3.4 Install Walking Beam.....	Pg. 11
3.5 Install Spindle/Hub Assembly.....	Pg. 12
3.6 Install Wheels.....	Pg. 12
3.7 Installation on Opposite Side.....	Pg. 12

1. Contents of Bundle

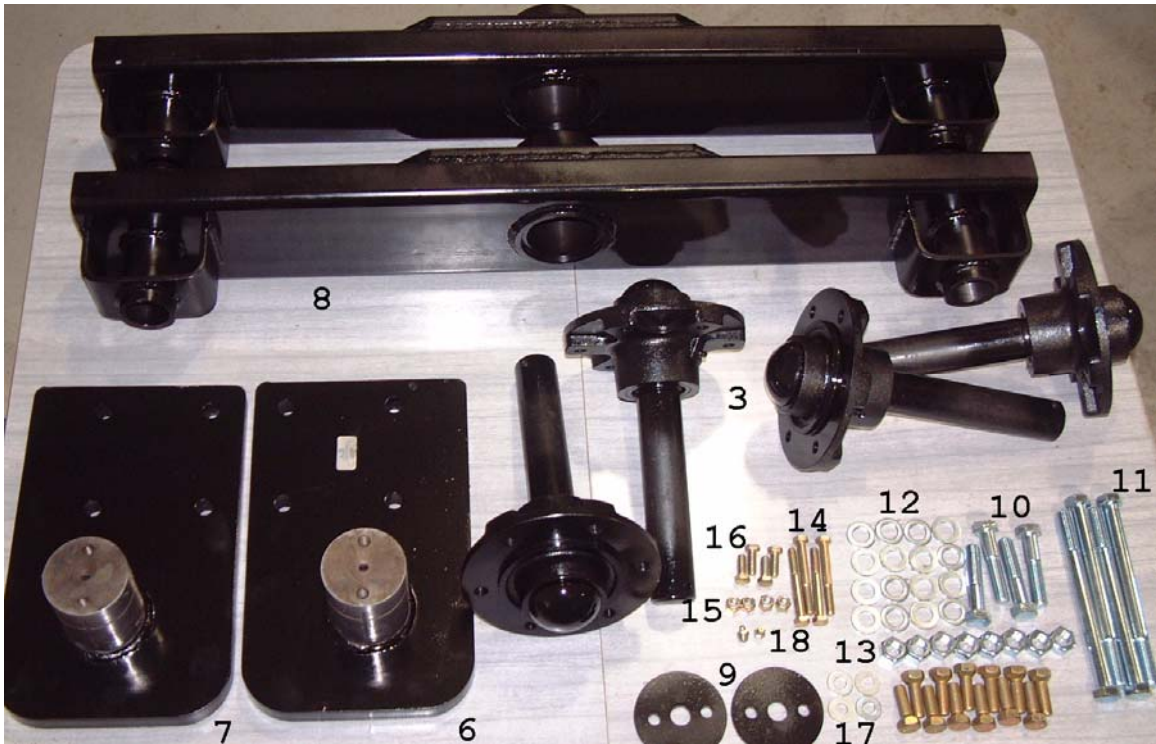

Note: Wheels and tires not shown.

Bundle includes two tires and rims, depending on part number of bundle.

1.1 Parts Listing

Note: For service parts, see your local John Deere dealer.

Key	RCI Part Number	Part Name	Quantity
1	RC0186	Rim - 11Lx14	2
2	RC0187	Rim - 31.5x15	2
3	RC0188	Spindle Assembly w/studs	4
4	RC0189	Tire - 31.5x15	2
5	RC0190	Tire - 11L-14	2
6	RC0213	Pivot Plate - RH Side	1
7	RC0212	Pivot Plate - LH Side	1
8	RC0214	Walking Beam	2
9	RC0209	Washer	2
10	RC0191	Bolt 5/8-11 x 3"	4
11	RC0192	Bolt 5/8-11 x 8"	4
12	RC0193	Washer, 5/8"	12
13	RC0194	Nut, 5/8"	8
14	RC0195	Bolt 3/8"x3"	4
15	RC0196	Lock Nut 3/8"	4
16	RC0197	Bolt 3/8"x1.25"	4
17	RC0182	Flat Washer 3/8"	4
18	RC0198	Grease Zerk	2
19	RC0199	Installation Instructions	1

2. Service Information

2.1 Service Intervals

Daily

1/ Grease center pivot pin of walking beam assembly.

25 Hours of Operation

1/ Grease wheel hubs. Grease fitting is located on back side of hub.

IMPORTANT:

NEVER lift machine under the spindles or anywhere on the walking beam.

Always lift machine with proper jack at a safe point on the main frame of the baler.

Always use blocks to support the machine when in raised position.

Please retain this document for future reference.

2.2 Position of Pivot Assemblies for Various Baler Positions

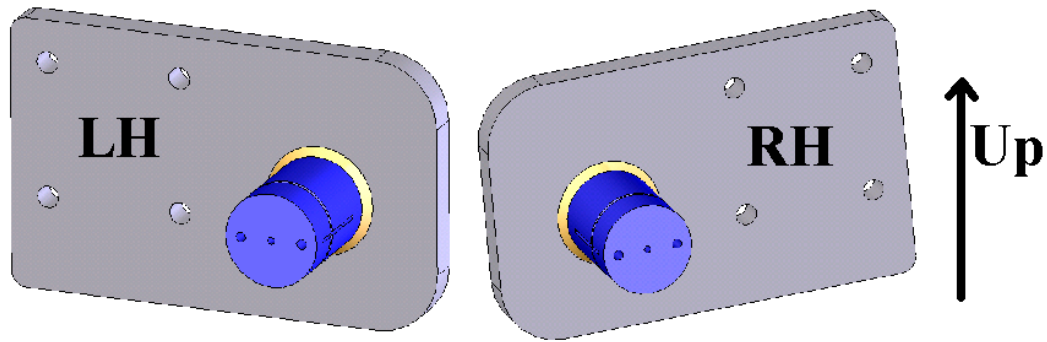

Standard Position

In the standard position, the pivot pin is behind the mounting location of the production spindle. Align the plates such that the holes closest to the edge of the plate are at the top.

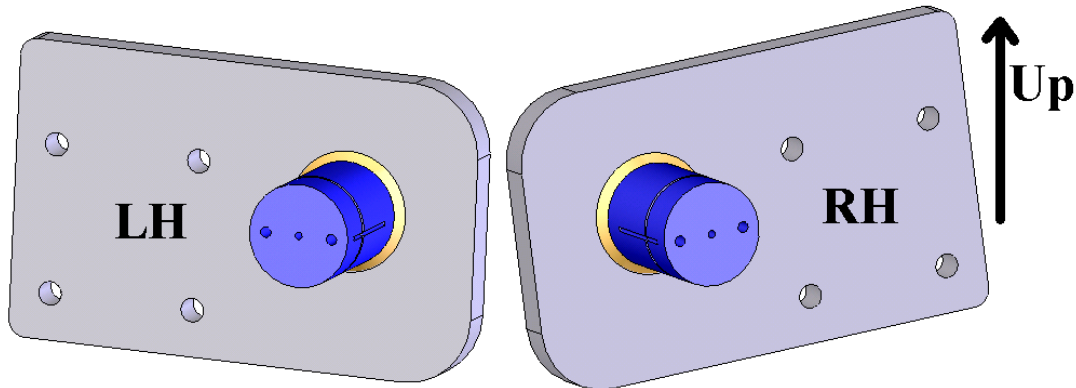

Lowered Position

In the lowered position, the pivot pin is still behind the mounting location of the production spindle, but the plates are switched from side to side so that the holes closest to the edge of the plate are aligned down as shown.

2.3 Spacer Location (as needed)

Note: Balers with Push Bar and without *Mega Wide* Pickup require (1) RC0185 Spacer Block Bundle.

The spacer is installed between the main frame of the round baler and the pivot plate for the tandem axle. This allows clearance from the pivot plate to the Push Bar.

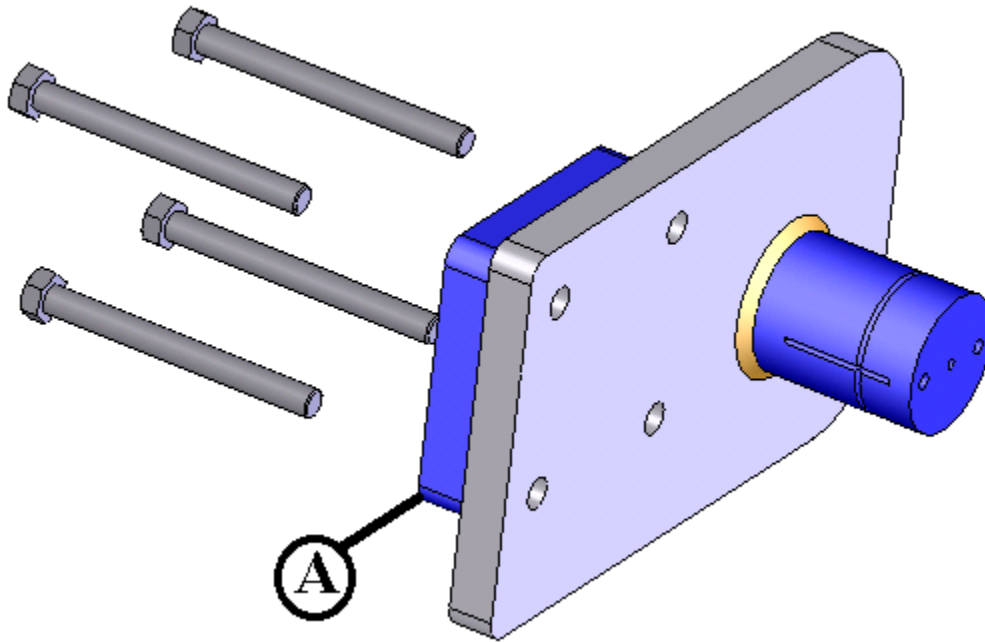

A – RC0185 Spacer

3. Installation of Tandem Axle Bundle

Remove Tire and Spindle Assembly

Using the proper equipment and jacking location, raise the right hand wheel of the machine off the ground. Use blocks to secure the machine once lifted.

Remove the wheel.

Remove the spindle.

Remove the four bolts used to secure the spindle casting.

Note: If Bale Push Bar is installed, unhook chains from gate (both sides), and manually move Push Bar to the rear for clearance to the bolts. **DO NOT OPEN THE REAR BALER GATE!**

3.2 Install New Bolts in Main Frame of Baler

For machines equipped with *Mega Wide Pickup*:

Install two (2) RC0192 Bolt (5/8 x 8") in the top two holes used for the spindle casting.

Install two (2) RC0191 Bolt (5/8 x 3") in the bottom two holes used for the spindle casting.

For balers without Push Bars and without *Mega Wide Pickup*:

Use same hardware used with spindle to install the pivot plate.

For balers with Push Bars and without *Mega Wide Pickup*:

Install four (4) RC0192 Bolt (5/8-11 x 8") in the four mounting holes that held the original spindle casting in place.

3.3 Install Pivot Plate

Install RC0213 Pivot Plate as shown on the baler for Standard Position. See Section 2.2 for explanation of baler positions.

Install four (4) RC0193 Washers (5/8") and four (4) RC0194 Nuts on the bolts previously installed. Torque nuts to specification.

Torque Specification: 225 ft-lbs

Install one (1) RC0198 Grease Fitting in the end of the shaft.

Grease pin surface (F) using same grease that is used for daily service of the baler.



Figure 1. Pivot Plate Installation

C-RC0193 Washer D-RC0194 Nut E-RC0198 Grease Fitting F-Shaft

IMPORTANT

Effective with all 7- and 8-Series Round Balers, install mounting bolts pictured in Figure 1 backwards from what is shown. The bolts should be installed with the heads to the outside of the machine and torque properly. Failure to do so may result in bolt failure.

For Balers with Push Bar and without *Mega Wide Pickup* require one (1) RC0185 Spacer Block Bundle:

A RC0185 spacer is installed between the main frame of the round baler and the pivot plate for the tandem axle. This allows clearance from the pivot plate to the *Bale Push Bar*.

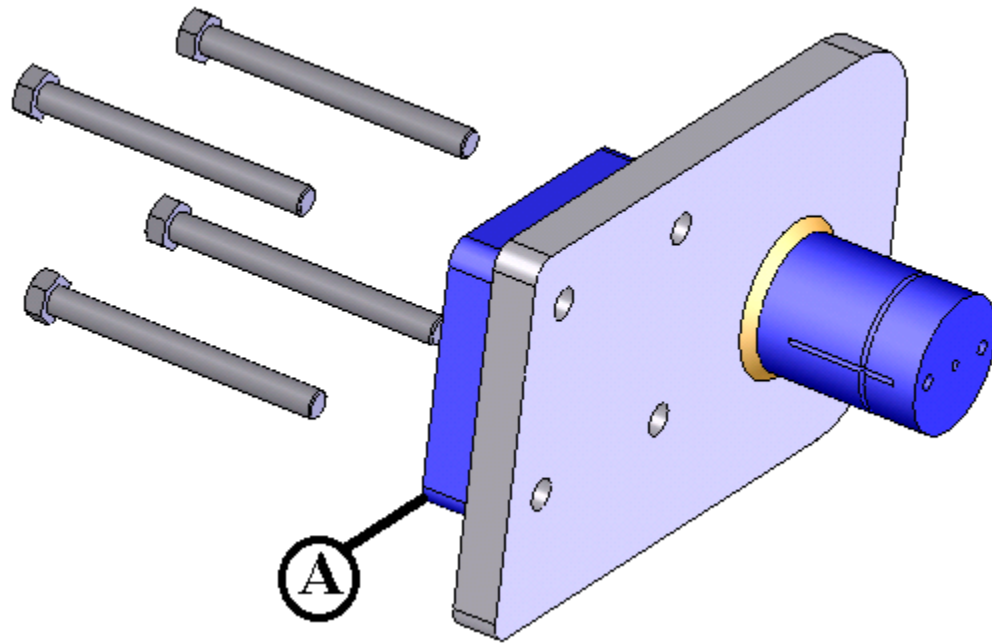

Figure 2 – Spacer Plate Installation (LH Side Shown)

A – RC0185 Spacer Plate

3.4 Install Walking Beam

Install RC0214 Walking Beam on the pivot pin with the tube extending towards the center of the machine as shown in Figure 3. Be sure to install the walking beam with the Greasing Reminder Decal on the top face as shown in Figure 3, below.

Install one (1) RC0209 Washer over the end of the pin with two (2) RC0182 Washers (3/8") and two (2) RC0197 Bolts (3/8" x 1.25") using high-strength *Loctite* on the bolts. Torque bolts to specification.

Torque Specification: 46 ft-lbs

Grease the center pivot pin until grease is visible outside of the walking beam.

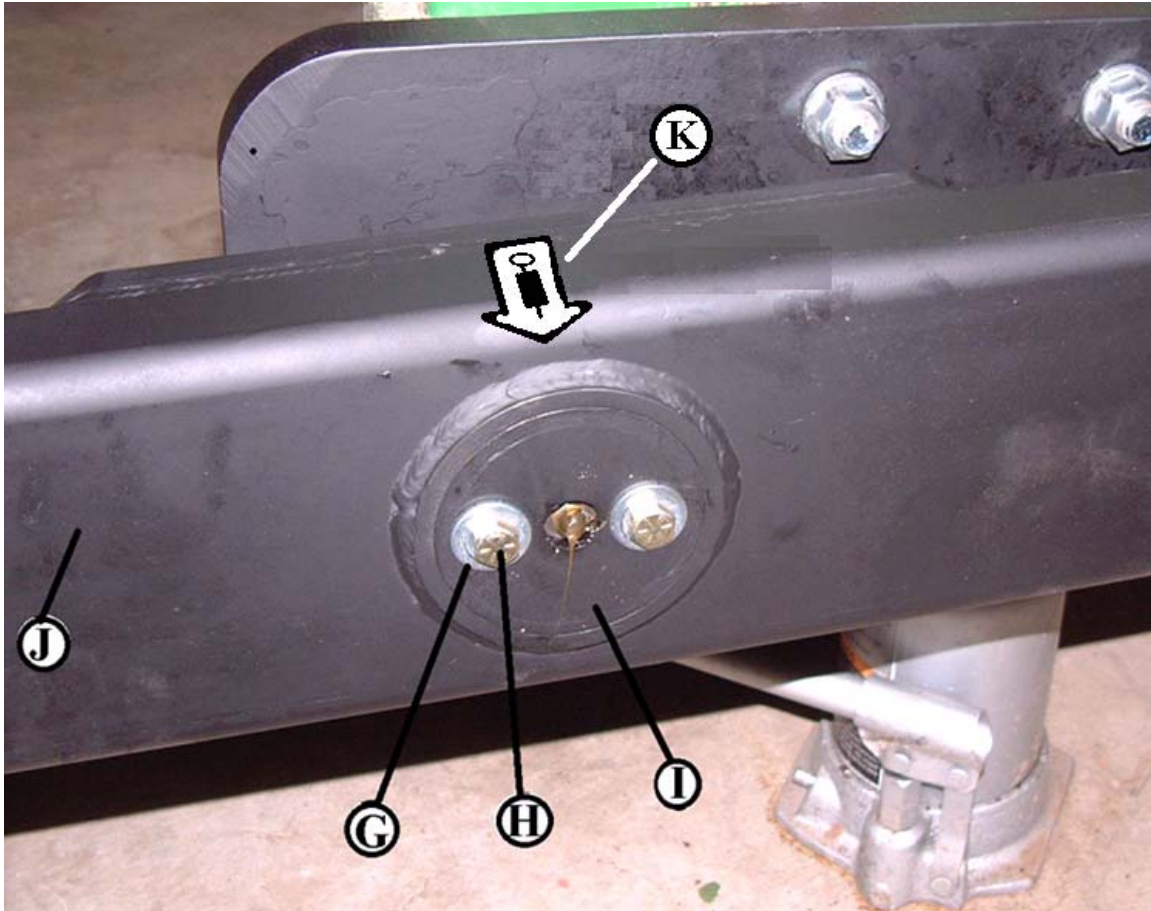

Figure 3. Walking Beam Installation

G-RC0182 Washer H-RC0197 Bolts I-RC0209 Washer Plate
J-Walking Beam K - Greasing Decal

3.5 Install Spindle/Hub Assembly

Install RC0188 Spindle/Hub Assembly into the tubes on the end of the walking beam. Secure each using one (1) RC0195 Bolt (3/8"x3") and one (1) RC0196 Lock Nut (3/8"). Torque bolts to specification.

Torque Specification: 46 ft-lbs

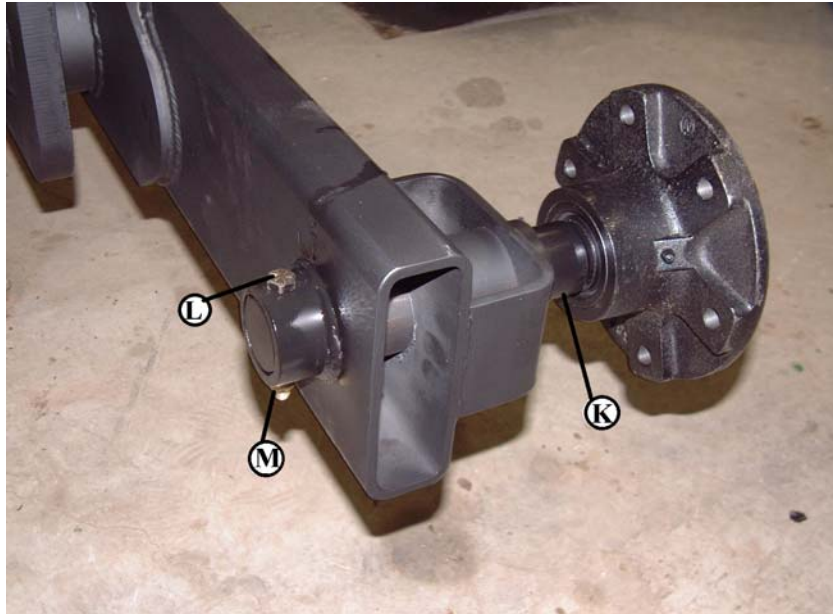

Figure 4. Installation of Spindle/Hub Assembly

K – Spindle/Hub Assembly L – RC0195 Bolt M – RC0196 Lock Nut

3.6 Install Wheels

Install wheels using wheel studs provided. Tighten properly.

Note: 31.5x15 Wheels must always be installed in the same manner as the original wheels on the machine from the factory.

Note: 11Lx14 Wheels can be installed either direction but it is recommended to install the wheels “dish-in” to minimize overall baler width.

With wheels fully installed and wheel studs tightened properly, remove blocks and safely lower baler to the ground.

3.7 Installation on Opposite Side

Repeat installation process on opposite side with remaining parts. Remember to grease the pivot pin before and after assembly to ensure that the entire contact surface is covered. Also remember to use high-strength *Loctite* on the two bolts on the end of the pivot pin.